

Prizelawn® BF₁ COMMERCIAL BROADCAST SPREADER

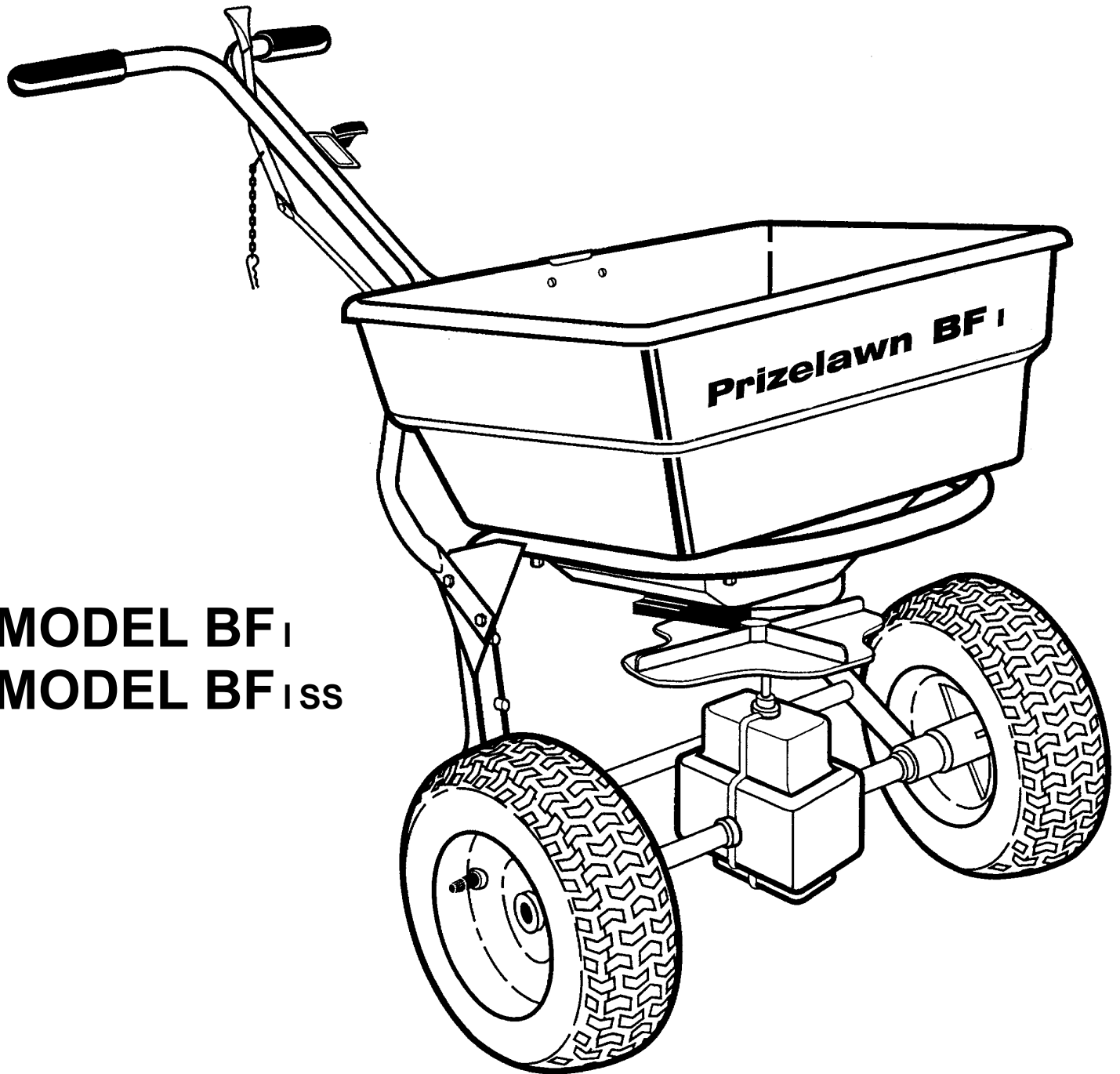

MODEL BF₁
MODEL BF₁SS

OWNER'S MANUAL

ASSEMBLY

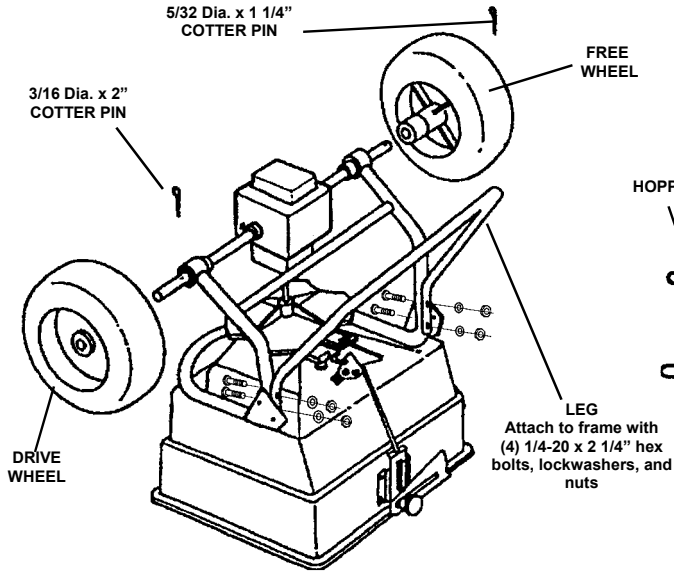

1 Remove spreader and components from carton and place spreader upside down. Slide drive and free wheels on axle as shown with the longer portion of wheel hub facing the frame. Secure free wheel with a 5/32 Dia. x 1 1/4" cotter pin. Secure drive wheel to axle with 3/16" Dia. x 2" cotter pin. Attach leg to frame as shown with (4) 1/4-20 x 2 1/4" hex bolts, lockwashers, and nuts. Tighten securely.

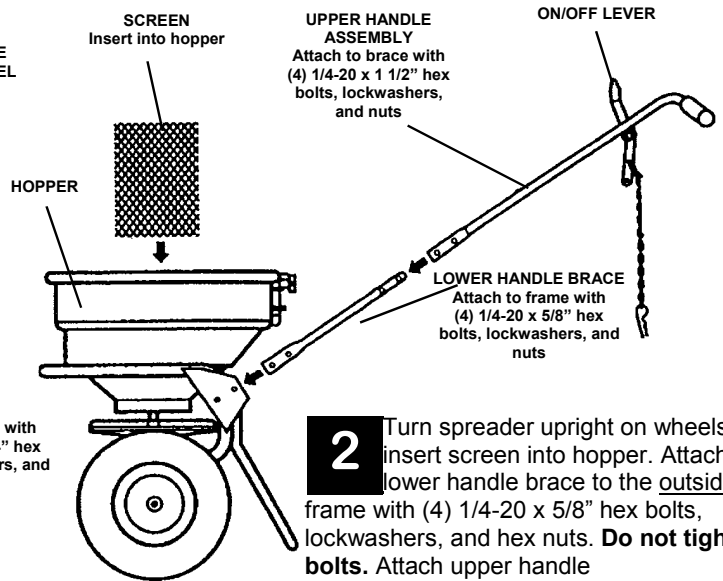

2 Turn spreader upright on wheels and insert screen into hopper. Attach lower handle brace to the outside of frame with (4) 1/4-20 x 5/8" hex bolts, lockwashers, and hex nuts. **Do not tighten bolts.** Attach upper handle

assembly to brace (make sure on/off lever is positioned as shown) using (4) 1/4-20 x 1 1/2" hex bolts, lockwashers, and nuts. Tighten securely. Install handle grips onto upper handle.

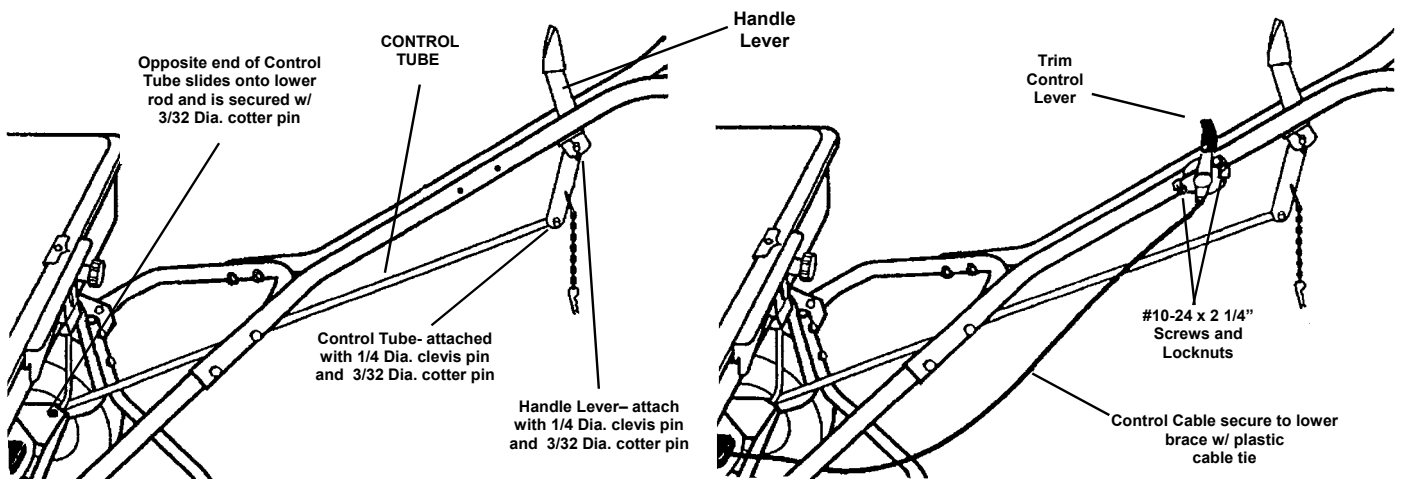

3 Slide handle lever between lever brackets as shown and secure with 1/4 Dia. clevis pin and 3/32 Dia. x 5/8" cotter pin. Install on/off control tube to control lever using 1/4 Dia. clevis pin and 3/32 Dia. x 5/8" cotter pin. Remove tape holding the lower rod to the pivot lever and slide opposite end of control tube onto lower control rod. Secure with a 3/32 Dia. cotter pin.

TIGHTEN ALL NUTS AND BOLTS LEFT LOOSE IN STEP #2.

4 **BF 1 STAINLESS MODEL ONLY**-Attach trim control lever to the upper handle using (2) #10-24 x 2 1/4" screws and locknuts. Secure control cable to lower brace with the plastic cable tie.

5 To check spreader for complete shutoff, pull the on/off control lever back to the "OFF" position. Determine if the port holes are completely closed. If they are not, loosen the brace/frame bolts and push down on the handle and front of spreader. Re-tighten bolts and check shutoff.

OPERATION

1 Check the product package for the rate setting (letter), pattern setting (number), and recommended swath width. Loosen the rate control knob and slide the rate plate to the proper rate setting. The pattern controls are adjusted by setting either the trim control plate or right auxiliary shut-off slide mounted on the shut-off plate. The trim control is remotely operated at the handle, while the auxiliary slide is set at the hopper. See "Pattern Adjustment" for further details.

2 Before filling hopper, make sure on/off control lever is in the "OFF" position. Make sure screen is in the hopper. Fill hopper.

3 Start spreader moving before opening ports, close ports before stopping spreader. Always push spreader. **DO NOT PULL.**

4 Hold handle so top of spreader is level. Tipping spreader too far can cause uneven spreading.

5 The settings and swath width on the product label are recommended starting points. Always check the delivery rate and pattern on a small area before treating a large area. Actual delivery rates can vary due to weather conditions, operating variables, and condition of the products being applied. See "How to Determine Spreader Setting and Swath Width" for details.

6 Push spreader at 2 1/2 m.p.h. (18 feet in 5 seconds). Apply header strips at each end of area to be treated then space trips across the area as shown.

7 To keep material off walks, flower beds, borders, etc., the pattern can be narrowed by pulling the trim control lever mounted on the handle to the "ON" position. The pattern will end just beyond the right wheel.

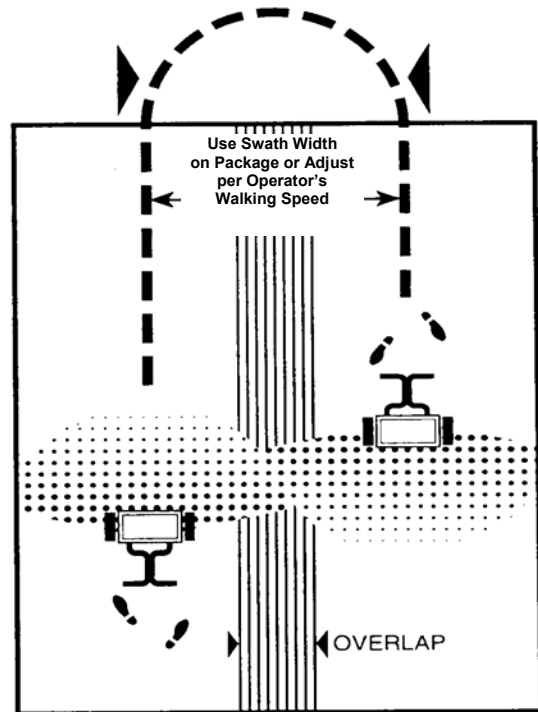

8 When transporting spreader from location to location, make sure the on/off control lever is locked in the "OFF" position securing the lever with the hitch pin.

9 Model BF_{ISS} only-Ice melt products can be applied using a normal width, or a narrow band can be applied by closing the trim control and the auxiliary shut-off slide, leaving only the center port open as shown.

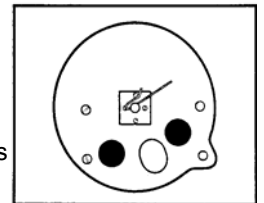

10 Empty the spreader after each use. Return leftover material to its original container.

PATTERN ADJUSTMENT

Normal spreading of material requires no adjustment unless otherwise stated on the package. In those cases where the spread pattern has shifted, the pattern can be adjusted. If the pattern is heavier to the left (as viewed from the operating position), loosen the knob and move the control plate in toward the hopper. If it is heavy to the right, move the control plate out away from the hopper. Tighten knob after each adjustment is made. A scale is stamped into the control plate to provide settings.

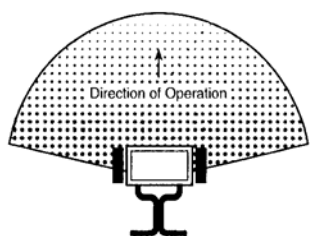

Normal Pattern

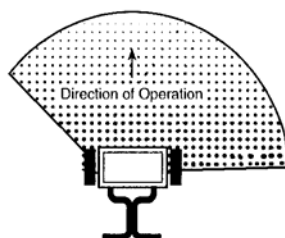

Pattern Heavy Right

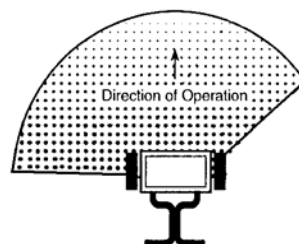

Pattern Heavy Left

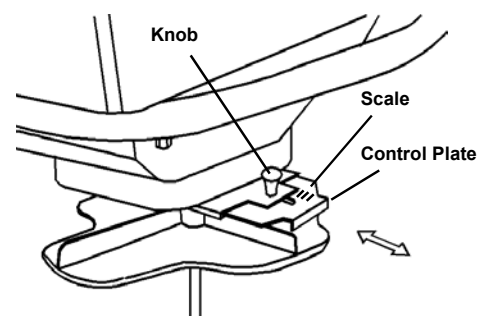

HOW TO DETERMINE SPREADER SETTINGS AND SPREAD WIDTH

Two major factors should be considered when determining correct spreader settings of any product:

1. The product application rate, or the amount of material applied per 1,000 square feet.
2. The effective pattern width, or the actual width in which material is applied. Label settings are a guide and can be affected by numerous factors

EFFECTIVE PATTERN WIDTH

A simple visual pattern test can be made by operating spreader over a non-turf area and evaluating the pattern. A more accurate method is to place a row of common, disposable, aluminum cake pans approximately 1 foot on centers. Set the rate plate at a middle setting and make 3 or 4 passes in the same direction as shown. Pour the material collected from each pan into individual bottles of the same size. Set them side by side in order, and visually inspect their volume. If the pattern is not centered (example: volume in bottle #2 left not equal to bottle #2 right) adjust the pattern control as described in the "PATTERN ADJUSTMENT" section.

Once the pattern is uniform, the effective pattern width can be determined. The effective pattern

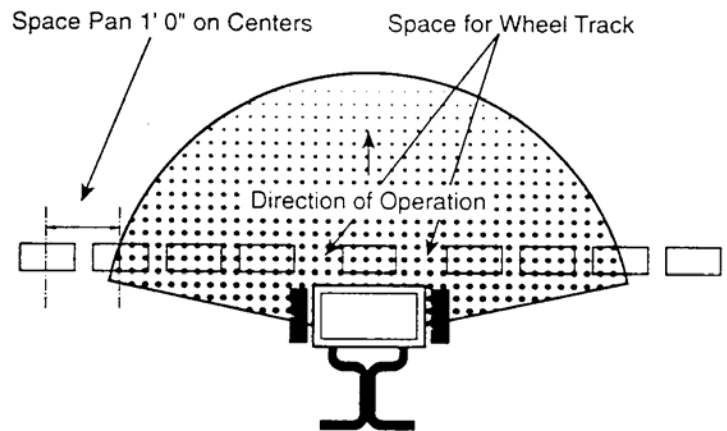

width is the distance out from the spreader to a point where the amount of material is 1/2 the average amount in the center pans. This distance is multiplied by 2 to achieve the total effective pattern width.

APPLICATION RATE

Knowing the effective pattern width (for example, 10 feet), measure a distance equal to 100 square feet (10' x 10' swath width). Determine the product coverage in pounds / 100 sq. ft. by taking the weight of product and dividing it by the recommended square foot coverage (add two zeroes to the weight of the bag).

EXAMPLE: Product Weight: 25 lbs.
Sq. Ft. Coverage: 5000 sq. ft.
 $2500 \text{ lbs.} \div 5000 \text{ sq. ft.}$
 $= .5 \text{ lbs} / 100 \text{ sq. ft.}$

Weigh out between 15 to 20 lbs. of material and spread over the 100 sq. ft. area. Weigh remaining material left in hopper and adjust rate setting as required. Repeat test until application rate is correct.

MAINTENANCE

- 1** Never store material in spreader. Return unused product to its original container.
- 2** Wash spreader thoroughly after each use and dry completely in the sun or heated area.
- 3** Grease the axle bearings on the frame. Oil the impeller shaft bearing in hopper, and pivot points on the shut-off linkage and the spring in the housing behind the rate plate as shown.
- 4** Remove the gear cover and wash gears thoroughly and oil all bearing areas as shown. Re-install gear cover.
- 5** Gear mesh should be checked on a regular basis during high use periods. Clearance between the axle gear and pinion gear should be minimal but not tight. If adjustment is necessary, loosen axle collar set screw and hold gears together. Slide axle collar against gear support and tighten axle collar set screw. Spin drive wheel. Gears should run freely and smoothly.
- 6** Impeller surface should be cleaned periodically to remove build-up of product. Build-up can cause the spread pattern to change.
- 7** Tire pressure should be 20-25 PSI.

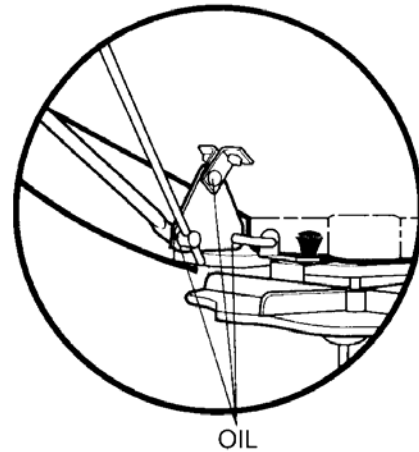
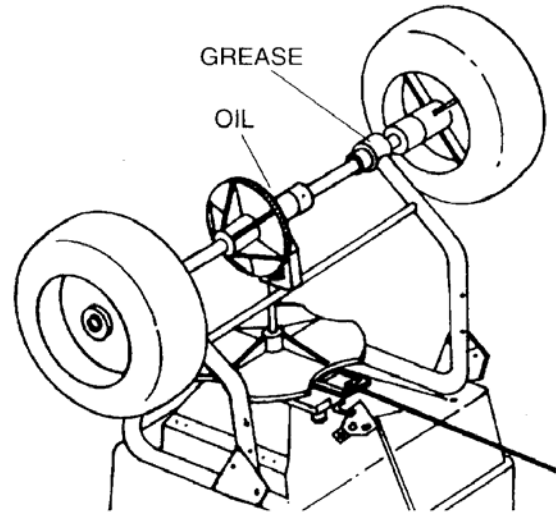

CALIBRATION INSTRUCTIONS

The BF1 spreader was factory calibrated, however, calibration should be checked occasionally to assure optimum performance.

- 1** Pull the on/off lever to the closed position. Set the rate control plate at setting "A".
- 2** Flip on/off lever forward to the "ON" position. Check the center port hole. It should be just open as shown. If adjustment is necessary continue to step #3.
- 3** Remove cotter pin from adjusting swivel and slide off control tube. Slide swivel out of hole in pivot bracket (NOTE SIDE OF PIVOT BRACKET FROM WHICH IT WAS REMOVED). Thread swivel up or down on lower rod as required. Install swivel back onto pivot bracket facing the same way it was removed. Check calibration. Repeat procedure until calibration is correct. Reinstall control tube and cotter pin.

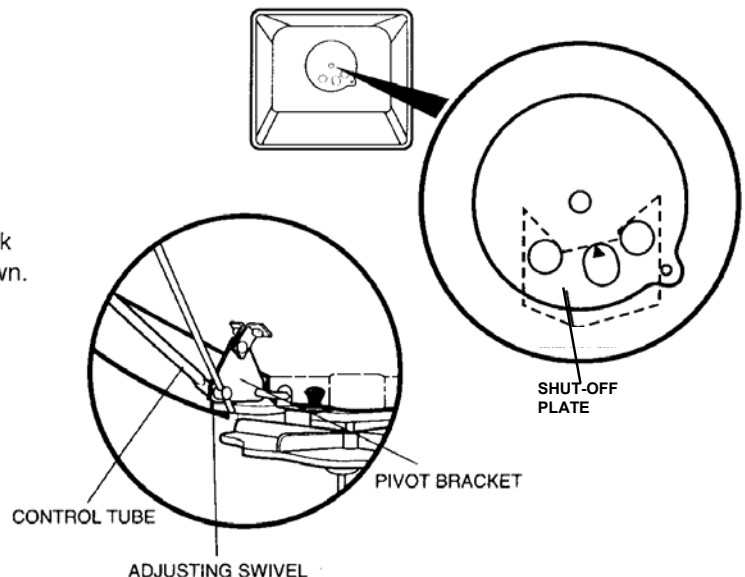





RATE SETTING CONVERSION

The following provides approximate Prizelawn® BF_I/BF_{ISS} settings for those units listed.

BF_I & BF_{ISS} Setting	A	B	C	D	E	F	G	H	I	J	K	L	M	N	O	P	Q	R	S	T	U	V	W	X	Y	Z
Lesco #029600 Setting	A	—	B	C	D	—	E	F	—	G	H	I	—	J	K	L	—	M	N	O	—	P	Q	R	—	S
Scotts R8A/SR-1 Setting	C	D	E	F	G	H	I	J	K	L	M	N	O	P	Q	R	S	T	U	—	V	W	—	X	Y	Z
Earthway 2200/2400 Setting	5	—	—	—	—	10	—	—	—	—	15	—	—	—	—	20	—	—	—	—	25	—	—	—	—	30
Spyker 76/78-2 Setting	—	—	3	—	—	—	4	—	—	5	—	—	6	—	—	7	—	—	8	—	—	—	9	—	—	10

The following provides approximate Prizelawn® BF_I/BF_{ISS} settings when only the product weight, square foot coverage, and visual inspection of material is available.

FERTILIZER PARTICLE SIZE	BAG RATE Pounds of fertilizer used per 1,000 sq. ft. of coverage	APPROX. SETTING	SPREAD WIDTH (IN FEET)
Large, heavy particles 	5	J	12
	10	K	12
	15	L	12
Medium- mixed particles 	5	G	10
	10	H	10
	15	I	10
Small particles (nitrogen) 	1	D	10
	2	F	10
	3	J	10
Mixed size particles -some fines 	5	I	8
	10	J	8
	15	K	8
Light weight particles 	5	F	6
	10	G	To
	15	H	8

The conversions should be used as guidelines for establishing proper rate settings for the particular product being applied. Steps for obtaining the most accurate settings are outlined in the "How to Determine Spreader Settings and Spread Width" section of this manual.

These settings are approximate and may vary due to physical characteristics of the product. Walking speed, wear, condition of the turf and humidity, may cause actual rate setting to deviate. No expressed nor implied warranty or guarantee is provided as to coverage or uniformity indicated by these rate settings.

Parts List for Model BF_I / BF_Iss

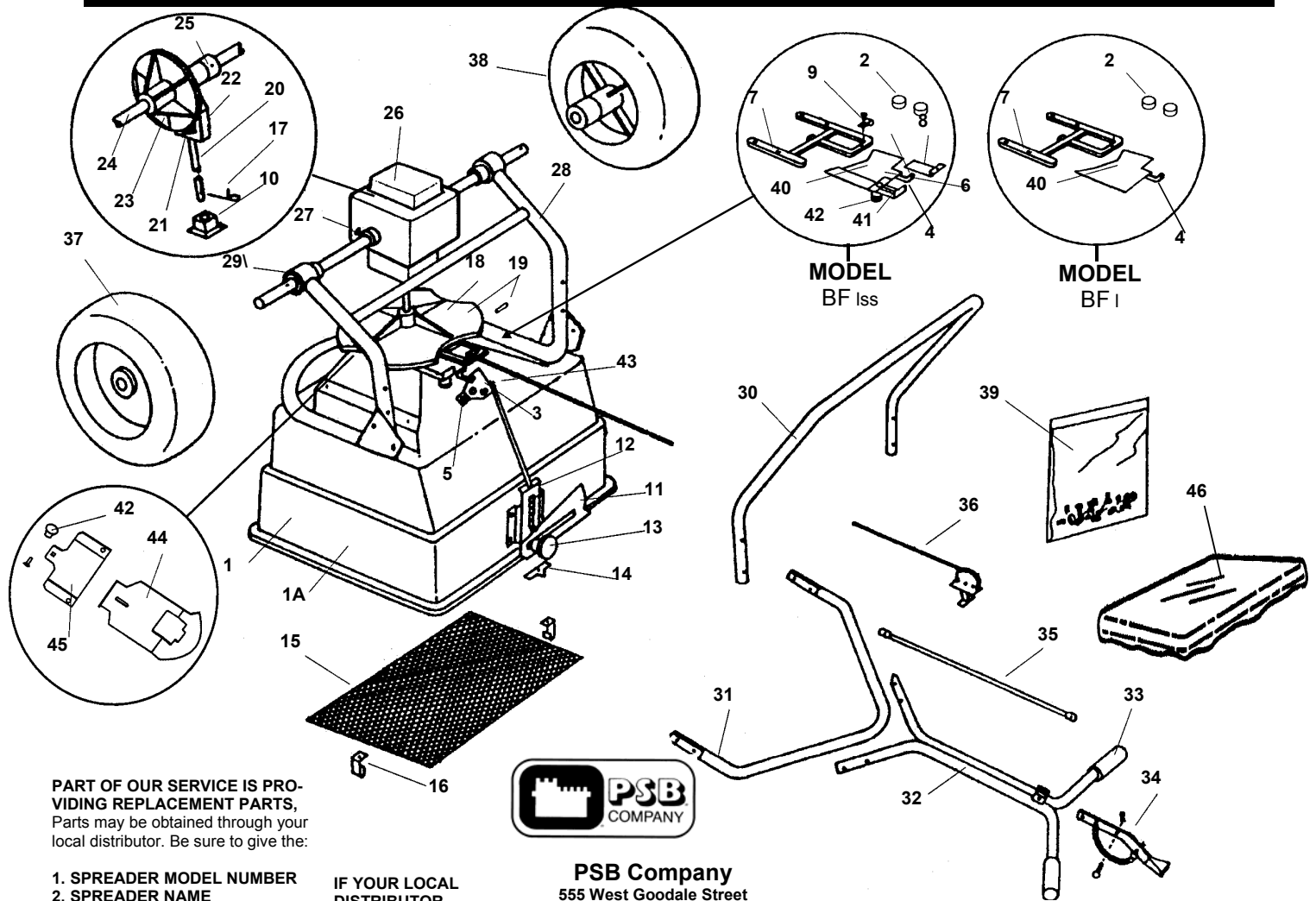

PART OF OUR SERVICE IS PROVIDING REPLACEMENT PARTS, Parts may be obtained through your local distributor. Be sure to give the:

1. SPREADER MODEL NUMBER
2. SPREADER NAME
3. PART NUMBER
4. NAME OF PART AS SHOWN

IF YOUR LOCAL DISTRIBUTOR CANNOT SUPPLY PARTS, CONTACT:



PSB Company

555 West Goodale Street
P.O. Box 1089
Columbus, Ohio 43216-1089
(614) 228-5781 EXT. 655

*Parts in hopper ass'y,
**Parts in impeller ass'y,
*** Parts in shut-off plate ass'y

#	BF _I	BF _I ss	DESCRIPTION	#	BF _I	BF _I ss	DESCRIPTION	#	BF _I	BF _I ss	DESCRIPTION
1	14815-1	14815-1	Hopper*	16	14864	14864	Screen Clip (2)	32	14825-1	14907	Upper Handle
1A	15416	14877-1	Hopper Assembly	17	14865	14865	Agitator	33	14870	14870	Handle Grips
2	14879	14879	Hopper Hole Plug (2)*	18	14866-2	14866-2	Impeller Assembly	34	14047	14047	Handle Lever Assembly
3	14878	14878	Pivot Lever Assembly*	19	14625	14625	Impeller w/ Roll Pin**	35	14871	14916	Control Tube
4	14846	14846	Shutoff Plate Link*	20	14867-3	14867-3	Impeller Shaft**	36	—	14859	On/Off Control w/ Clamp
5	14848	14848	Reinforcing Plate*	21	14833	14833	Pinion Gear w/ Roll Pin**	37	14856	14856	Drive Wheel w/ Cotter
6	—	14840	Shutoff Plate Assembly*	22	14834	14834	Gear Support**	38	14857	14857	Free Wheel w/ Cotter Pin
7	14836	14836	Shutoff Plate Guide*	23	14832	14832	Axle Gear w/ Roll Pin	39	15425	15426	Fastener Package
8	—	14847	Aux. Shutoff Plate-LH.*	24	14860	14860	Axle	40	14838	14838	Shutoff Plate***
9	—	90060	Wire Clamp	25	14971	14971	Axle Collar (3)	41	14839-1	14839-1	Aux. Shutoff Plate-RH***
10	14312-1	14312-1	Impeller Bearing Ass'y*	26	14837	14837	Gear Cover (2)	42	14001	14001	Knob w/ Carriage Bolt***
11	14861	14915	Rate Control Plate*	27	14868	14868	Gear Cover Clamps (3)	43	14913	14913	Adjusting Swivel
12	14885-1	14885-1	Spring Housing Assy*	28	14886	14898	Frame Ass'y. w/ Bearings	44	14985	14985	Pattern Control Plate
13	12704	12704	Rate Knob w/ Washer*	29	14855	14855	Axle Bearings (4)	45	14884	14884	Pattern Control Guide
14	12708	12708	Pointer W/ Screw & Nut*	30	14828-1	14904	Leg w/ Tube Caps	46	14872-1	14872-1	Hopper Cover
15	14863	14863	Hopper Screen	31	14824-1	14905	Lower Handle Brace				

OPTIONAL ACCESSORIES

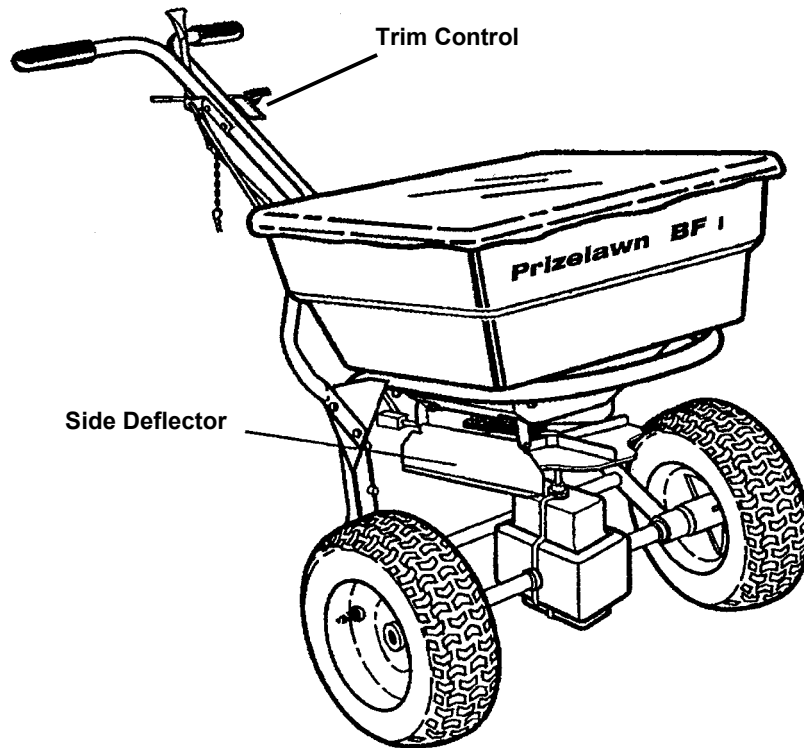

#14889 **Side Deflector Kit-**
Model BF 1 /BF 1SS

#15424 **Trim Control Kit-**
Model BF 1 only
(includes LH & RH. Aux.
Shutoff Plates)

LIMITED WARRANTY

PSB warrants to Purchaser the following:

1. Product will be free of defects in materials and workmanship for a period of one year from date of purchase.
2. The axle gear, gear support, pinion gear, axle, and axle bearings have a limited lifetime warranty to be free of defects in materials and workmanship.
3. PSB will decide in its reasonable discretion if the part(s)/unit is defective.
4. The spreader or part(s) will be shipped to PSB at the customer expense with a written description of defect to the attention of PSB WARRANTY DEPARTMENT.
5. If the spreader is used for commercial rental the Limited Warranty shall be limited to a period of 90 days.
6. All Unit and part replacement will be performed at the reasonable discretion of PSB.
7. Labor charges are not covered and the unit need not be returned to the dealer for warranty service.
8. Proof of purchase must be supplied to PSB.

PSB's sole obligation under this warranty is limited to repairing or replacing the defective part. Upon replacement of any Product or Product part, the replaced item shall become the property of PSB. If PSB determines that the Product covered by this warranty requires service, PSB shall prepay return shipping charges from PSB. In all other instances, such charges shall be paid by Purchaser. Except for loss or damage caused by PSB's negligence, Purchaser relieves PSB of responsibility for all risks of loss or damage to the Product and its parts during the period the products are in transit to and from PSB.

This warranty does not extend to any Product or parts thereof that have been allowed to corrode, subjected to misuse, neglect, accident, or modification by anyone other than PSB or that have been affixed to any nonstandard accessory attachment or that have been used, stored, installed, maintained or operated in violation of PSB's instructions or standard industry practice. No agent, employee or representative of PSB has any authority to bind PSB to any affirmation, representation or warranty concerning the Product and any affirmation, representation or warranty made by any agent, employee or representative shall not be enforceable by Purchaser.

THIS WARRANTY EXTENDS ONLY TO THE ORIGINAL PURCHASER AND IS EXPRESSLY IN LIEU OF ANY OTHER EXPRESS OR IMPLIED WARRANTIES, INCLUDING WITHOUT LIMITATION ANY IMPLIED WARRANTY OR MERCHANTABILITY OR FITNESS OR INTENDED USE FOR A PARTICULAR PURPOSE AND OF ANY OTHER OBLIGATION ON THE PART OF PSB.

PSB SHALL NOT BE LIABLE FOR ANY INCIDENTAL, SPECIAL OR CONSEQUENTIAL LOSS, DAMAGE OR EXPENSE DIRECTLY OR INDIRECTLY ARISING FROM THE USE OF ANY OF THE PRODUCT INCLUDING, BUT NOT LIMITED TO, DAMAGE OR LOSS OF OTHER PROPERTY OR EQUIPMENT, LOSS OF PROFITS OR REVENUE, COST OF CAPITAL, COST OF PURCHASED OR REPLACEMENT GOODS, OR CLAIMS OF CUSTOMERS OF PURCHASER.